

MBJ20 Transcutaneous Jaundice Detector

Instruction Manual

V4.0

Beijing M&B Electronic Instruments Co., Ltd

July 2013

About this manual

Firstly, thank you very much for using our M&B product.

To ensure correct use of MBJ20 transcutaneous jaundice detector (herein below mentioned as MBJ20 or jaundice detector), read the following points carefully and adhere to them. After reading this manual, keep it in a safe place where it can be referred to anytime a question arises.

Model Number: MBJ20

Product Name: Transcutaneous Jaundice Detector

Manufacturer: **Beijing M&B Electronic Instruments Co., Ltd**

Address: Room 6319, Building 1, No. 27, Yongwang Road, Beijing

Bioengineering and Medicine Industry Base, Huangcun Town,

Daxing district, Beijing, People's Republic of China

Issued date: July 18, 2013, Version: V4.0

Intellectual property

The **intellectual property** of MBJ20 and its manual belong to **Beijing M&B Electronic Instruments Co., Ltd** (herein below mentioned as M&B). Copying, reproduction or translation of all or any part of the contents of this manual without M&B's permission is strictly prohibited. All rights reserved by M&B.

Statement

M&B has the final rights to interpretation for this manual.

M&B is responsible for the product's safety, reliability and performance if below conditions are satisfied:

- Assembly, extensions, modifications or repair are carried out by persons authorized by M&B.
- The electrical equipment conforms to CE standards.
- MBJ20 is used in accordance with the instructions manual.

Maintenance Service

Free service range:

■ Free services are offered in accordance with M&B warranty regulations.

Fee based service range:

■ Beyond M&B warranty regulations.

■ During the warranty period, warranty shall not extend to the following conditions:

1) It is damaged from improper use.

2) Battery voltage is beyond the scope of product specification.

3) Natural disasters.

4) Replaced accessories, consumables without M&B authorization.

5) Modification or repair by anyone except M&B authorized person or company.

Contact us

Service telephone and product support:

Please contact M&B if you have any questions regarding product support.

+0086 010 61253803 (Working Time: Monday ~ Friday, 8:30 ~ 17:30);

Or contact the regional service partner or distributor.

Order consumables and repair parts

Please purchase repair parts (circuit board etc) from the M&B service partner or distributor in your country.

Other questions

Please contact us as below or visit our website: www.mbelec.com.

Headquarters

Company: M&B Electronic Instruments Co., Ltd.

Address: Room 6319, Building 1, No. 27, Yongwang Road, Beijing
Bioengineering and Medicine Industry Base, Huangcun Town,
Daxing district, Beijing, People's Republic of China

Information for The European Union representative:

European Union Representative Name: Shanghai international (European)

group company.

European Union Representative Address: No. 80, Hamburg Love Buddha Road
, Germany.

Content

| | |
|--|-----------|
| 1. Brief introduction | 1 |
| 1.1 INTENDED USER..... | 1 |
| 1.2 FUNCTION AND INTENDED USE | 1 |
| 1.3 COMPOSITION OF PACKAGE..... | 1 |
| 1.4 SIZE AND NET WEIGHT..... | 1 |
| 1.5 TRANSPORTATION AND STORAGE CONDITIONS..... | 2 |
| 1.6 OPERATING CONDITIONS..... | 2 |
| 1.7 VOLTAGE SUPPLY | 2 |
| 2 Safety precautions | 3 |
| 2.1 SAFETY INFORMATION..... | 3 |
| 2.1.1 <i>Terms and Symbols</i> | 3 |
| 2.1.2 <i>Instrument Safety</i> | 3 |
| 2.2 ATTENTION AND WARNINGS | 4 |
| 2.2.1 <i>Environment</i> | 4 |
| 2.2.2 <i>Preparation</i> | 4 |
| 2.2.3 <i>Power</i> | 5 |
| 2.2.4 <i>Protection</i> | 5 |
| 2.2.5 <i>Preventative Inspection and Maintenance</i> | 5 |
| 2.2.6 <i>Other Notices</i> | 6 |
| 2.3 TRANSPORTATION AND STORAGE | 7 |
| 2.4 INTERFERENCE INSTRUCTION | 7 |
| 2.5 CLASSIFICATION | 7 |
| 2.6 SAFE OPERATION AND PROCESSING CONDITIONS | 7 |
| 2.7 DEVICE SYMBOLS..... | 8 |
| 2.8 STANDARDS AND REGULATIONS COMPLIANCE | 9 |
| 3 Control and Function | 10 |
| 3.1 FUNCTION..... | 10 |
| 3.2 MAIN STRUCTURE | 10 |

| | | |
|----------|---|-----------|
| 3.2.1 | <i>Front panel</i> | 10 |
| 3.2.2 | <i>Display Screen</i> | 11 |
| 3.3 | SPECIFICATIONS | 12 |
| 4 | Preparations before Use | 13 |
| 4.1 | BASIC KNOWLEDGE | 13 |
| 4.1.1 | <i>Precocious Jaundice</i> | 13 |
| 4.1.2 | <i>When the Newborn Infant Is Undergoing Phototherapy</i> | 13 |
| 4.1.3 | <i>Measurement Points</i> | 14 |
| 4.2 | ATTENTION DURING OPERATION | 14 |
| 4.3 | OPERATION LOCATION | 15 |
| 4.4 | CHECK BATTERY | 15 |
| 5 | Operation Instructions | 17 |
| 6 | User Recommendations for Use During and After Phototherapy | 20 |
| 6.1 | DURING PHOTOTHERAPY | 20 |
| 6.1.1 | <i>Eye Patches</i> | 20 |
| 6.1.2 | <i>Adhesive Skin Patches</i> | 20 |
| 6.2 | AFTER PHOTOTHERAPY | 21 |
| 7 | Special Operation | 22 |
| 7.1 | DATA DELETION | 22 |
| 7.2 | UNIT CONVERSION | 22 |
| 7.3 | RECORDS PLAYBACK | 23 |
| 7.4 | CALIBRATION | 23 |
| 7.4.1 | <i>Settings of Calibration Coefficient</i> | 23 |
| 7.4.2 | <i>Calibration Method</i> | 24 |
| 7.5 | AVERAGE TEST FUNCTION | 25 |
| 7.5.1 | <i>Average Times Setting</i> | 25 |
| 7.5.2 | <i>The Average Test Method</i> | 25 |
| 8 | Maintenance | 27 |
| 8.1 | BIOCOMPATIBILITY | 27 |
| 8.2 | DAILY INSPECTION | 27 |

| | |
|---|-----------|
| 8.3 STORAGE METHOD..... | 27 |
| 8.4 MAINTENANCE PLAN..... | 28 |
| 8.4.1 <i>Inspecting Device</i> | 28 |
| 8.4.2 <i>Regular Cleaning</i> | 28 |
| 8.4.3 <i>Other Maintenance and Service</i> | 29 |
| 8.5 TECHNICAL SERVICE..... | 30 |
| 8.5.1 <i>Technical Maintenance</i> | 30 |
| 8.5.2 <i>Technical Inspection</i> | 30 |
| 8.6 THE REPLACEMENT OF ACCESSORIES AND CONSUMABLE MATERIALS.... | 30 |
| 8.7 DIAGNOSIS OF DEVICE MALFUNCTION | 30 |
| 9 Guidance and Manufacturer’s Declarations | 32 |

1. Brief introduction

1.1 Intended User

This manual is suitable for professional doctors and clinical personnel in obstetrical, gynecological, neonatal and pediatric departments. The clinical personnel must have application knowledge of relevant medical procedures, practical experience and professional qualifications in neonatal care.

1.2 Function and Intended Use

MBJ20 is used in the dynamic clinical examination of neonate jaundice, by determining the concentration of bilirubin transcutaneously. It is used for the initial screening and monitoring of bilirubin values in jaundice treatment.

1.3 Composition of Package

Table 1- 1

| No. | Name | Unit | Quantity | Note |
|--------|------------------------|--------|----------|--------------|
| | Main Equipment | piece | 1 | MBJ20 Device |
| | Instruction Manual | piece | 1 | |
| 206025 | Calibrator | piece | 1 | *optional |
| 205040 | Certificate of quality | piece | 1 | |
| 205041 | Warranty Card | piece | 1 | |
| 205140 | Battery | pieces | 2 | AA1.5V |

1.4 Size and Net Weight

1.MBJ20 size: 176mm×59mm×35.5mm (Length×Width×Height)

2.MBJ20 Net Weight: 215g (including two alkaline batteries)

1.5 Transportation and Storage Conditions

1. Environment temperature of -20 deg C ~ +55 deg C;
2. Relative humidity of $\leq 93\%$;
3. Atmospheric pressure of 500hPa~1060hPa.

1.6 Operating Conditions

1. Environment temperature of +10 Deg C~+40 Deg C;
2. Relative humidity of $\leq 80\%$;
3. Atmospheric pressure of 860hPa~1060hPa.

1.7 Voltage Supply

The device requires DC 3.0V, AA1.5×2 alkaline batteries.

2 Safety precautions

2.1 Safety Information

2.1.1 Terms and Symbols

2.1.1.1 Terms

This manual is using the term of "ATTENTION", "WARNING" and "DANGER", etc. from beginning to end, which aims to indicate the danger and specified severity degree or level. Please be familiar with its definition and importance.

⚠ ATTENTION: Denotes potential danger or unsafe treatment which may result in slight injury or damage to the device or other property. The note provides application hints or other useful information. Read the note carefully to ensure safe and correct use.

⚠ WARNING: Denotes potential danger or unsafe treatment which may lead to death or serious physical injury.

⚠ DANGER: Definition of danger is based on potential injury source to people. Danger denotes urgent risk which may lead to death or serious physical injury.

2.1.1.2 Explanation of Safety Symbols

⚠ Denotes a note or warning content;

⊘ Denotes a prohibited operation. The operation must never be performed;

❗ Perform the operation accurately. The instruction must be strictly adhered to.

2.1.2 Instrument Safety

This section presents the safety instructions according to the general

specifications of the equipment, and in most cases, the statement applies to all aspects of the jaundice detector. The design of MBJ20 meets with the international safety requirements EN60601-1.

⚠ WARNING: ⚠ Denotes that failure to adhere to the following points may result in death or serious injury, and may also cause equipment damage or fire danger.

⚠ ATTENTION: ⚠ Please follow the instruction manual to ensure correct and safe operation. If you have any questions or find any errors, please contact M&B authorized service facility.

2.2 Attention and Warnings

As the manufacturer of medical devices, the company strives to ensure the security, reliability and performance of the instrument. For correct use of this instrument, read the following points carefully and adhere to them. After reading this manual, keep it in a safe place where it can be referred to anytime a question arises.

2.2.1 Environment

⚠ WARNING: ⚠ Jaundice Meter should not be used in situations that include environmental vibration, dust, corrosive or flammable, explosive gas (anesthetic gas, gasoline), extreme temperatures and humidity, and there is enough space for easy operation.

⚠ ATTENTION: ⚠ Ambient temperature exceeding the range of technical specification will affect the jaundice meter accuracy, resulting in machine damage or reduced machine life.

2.2.2 Preparation

Before starting measurements using this instrument, follow the procedure

given below.

⚠ ATTENTION: ⚠ Operator must verify whether work procedures and conditions are appropriate for the use of this instrument.

2.2.3 Power

⚠ ATTENTION: ⚠ If the device is not in use, the battery will discharge. Remove the batteries to store. Before use, check the battery adequacy.

2.2.4 Protection

⚠ WARNING: ⚠ Prohibit operating MBJ20 during magnetic resonance imaging (MRI) scan. (MBJ20 running may affect the MRI images and MRI may affect accuracy of MBJ20.)

⚠ ATTENTION: ⚠ Magnetic and electrical fields can interfere with the normal operation of the instrument. Therefore, make sure that all external devices working in the vicinity of the jaundice meter comply with the relevant EMC requirements. X-ray equipment or MRI devices can emit a high level of electromagnetic rays and they may be a source of interference. In addition, please ensure cell phones or other telecommunications equipment are kept away from the instrument.

2.2.5 Preventative Inspection and Maintenance

⚠ Warning: ⚠ In order to avoid possible problems and to ensure normal operation, preventative maintenance is essential. Generally, preventative maintenance should be conducted at least annually. The maintenance should include an overall check of the device. If the following occurs, users must stop using the device until rectified by a qualified service person:

- if the detector suffers excessive impact force, such as dropping.
- if any solid or liquid touches the external case or permeates into the device.
- if the instrument does not operate normally.
 - if external casing is ruptured or damaged.

⚠ WARNING: ⚠ Inspection:

- perform a routine inspection before using the device at least every 3 months, including the instrument case, probe and batteries.
- perform a preventative maintenance and inspection by an authorized service person every 12 months to ensure safety.

2.2.6 Other Notices

⚠ ATTENTION: ⚠ In order to avoid electric shock or detector failure, do not allow any liquid to permeate into the meter. If liquid has permeated into it, please contact your local service partner or distributor of M&B to inspect the detector.

⚠ ATTENTION: ⚠ Do not use the detector near flammable anesthetic gases, steam or liquid.

⚠ ATTENTION: ⚠ Note that the device must be disposed of as described in the manual. If you have any questions about proper disposal of the device, please contact Beijing M&B Electronic Instruments Co. Ltd or your local representative.

⚠ ATTENTION: ⚠ For safe operation of the device, the user must follow this instruction manual. However, these instructions do not supersede established medical procedures concerning patient care.

⚠ ATTENTION: ⚠ Only people who have been trained properly should

use this device.

2.3 Transportation and Storage

⚠ ATTENTION: **🔊** Put the MBJ20 into the included storage case during transportation.

2.4 Interference Instruction

⚠ ATTENTION: **🔊** The MBJ20 has functions that do not affect normal operation of other devices, and are these functions are not affected by other devices (except MRI equipment).

2.5 Classification

Table 2- 1

| | |
|---|-------------------------|
| Type of protection against electric shock | Internal power device |
| Degree of protection against electric shock | Type B applied part |
| Degree of protection against liquid penetration | IPO, ordinary equipment |

⚠ ATTENTION: **🔊** The classification of the electrical shock, fire disaster, machinery and other special risks are according to EN60601-1.

2.6 Safe Operation and Processing Conditions

Table 2- 2

| | |
|--|---|
| The sterilization or disinfection method recommend by manufacturer | Not applicable |
| Electromagnetic interference | Avoid the using of wireless telephones or other strong interference equipment near the detector |

| | |
|---------------------------------------|-----------|
| Electric surgical interference damage | No damage |
| Work Mode | Interval |

2.7 Device Symbols

⚠ ATTENTION: ⚠ Some symbols may not appear on all devices.

ON  OFF Power: ON equal to turn on; OFF equal to turn off

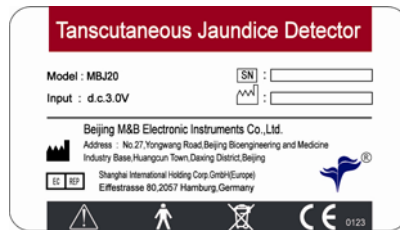

Figure 2- 1 Nameplate of MBJ20 Jaundice Detector

Explanation of the product external logos and marks are as follows:



Serial number



Date of manufacture



Manufacture information



Trademark



European delegate information: company and address



Warning



B type applied part



Waste of electrical and electronic equipment must not be disposed as unsorted municipal waste and must be collected separately.



CE mark

External package symbols:



The maximum range of temperature in transport should be between -20 deg C and 55 deg C.



Rain prevention



The maximum number of layers stacked is 4.



The correct direction for stacking in transport is straight up



Fragile, be careful when carrying.

2.8 Standards and Regulations Compliance

MDD-Medical Device Directive (MDD) 93/42/EEC;

EN 60601-1-2006: Medical Electrical Equipment-General Requirements
for Safety;

EN 60601-1-2-2001: Medical Electrical Equipment-Safety
Requirements-EMC;

EN 980-2008: Symbols for use in the labeling of medical devices;

EN 1041-2008: Information supplied by the manufacturer of medical
device.

3 Control and Function

3.1 Function

MBJ20 Transcutaneous Jaundice Detector is a handheld device used in the dynamic clinical examination of neonate jaundice. The transcutaneous bilirubin concentration which is correlative with serum bilirubin concentration can be measured instantly and non-invasively when the detector is placed on the neonatal skin. Combining electronics, optics and information processing technology, MBJ20 achieves many features: accurate, safe and fast detection, light weight, long life, low energy consumption, easy to use and maintain.

3.2 Main Structure

3.2.1 Front panel

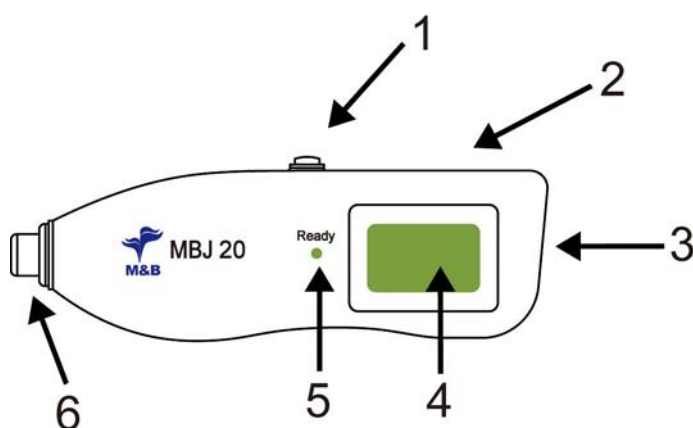

Figure 3- 1 Explanation of front view and indicators

Table 3- 1

| No. | Name | Function Description |
|-----|--------------|--|
| 1 | Reset Button | Clear the current measured value and prepares for the next measurement. Use this button in combination with the POWER switch and SET button to delete or playback previous measurements. |
| 2 | Set | Press the button to shift between $\mu\text{mol/L}$ and |

| | | |
|---|-----------------|--|
| | Button | mg/dL. Use this button in combination with the Power switch and RESET button to delete or playback previous measurements. |
| 3 | POWER Switch | Slide this switch to turn the power on/off. Use this switch in combination with the Set button and Reset button to delete or playback previous measurements. |
| 4 | Display | Display the measured value. |
| 5 | READY lamp | Lights up to indicate that the instrument is ready for measurement. |
| 6 | Measuring Probe | Takes measurement when pressed against the measuring point on the patient's body. |

3.2.2 Display Screen

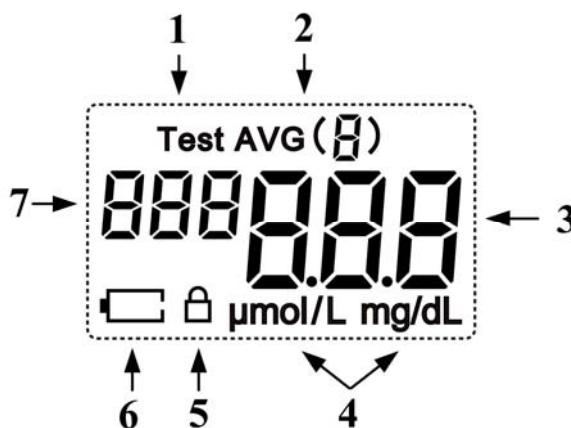

Figure 3- 2 LCD screen

Table 3- 2 Explanation of LCD content

| No. | Name | Function Description |
|-----|---------------|---|
| 1 | Test | Means that the operator has pressed the RESET button |
| 2 | AVG | it will display under the state of average measurement and show the average times |
| 3 | Value display | Displays the measurement value |

| | | |
|---|------------------------------|--|
| 4 | unit of measurement value | μmol/L, mg/dL |
| 5 | Parameter lock | Parameters have been saved after setting |
| 6 | Battery display | Battery displays empty when the battery power is low |
| 7 | Serial number of measurement | Indicating the sequence number of measurement |

3.3 Specifications

- 1) Display: LCD, 3 figures
- 2) Power: AA 1.5V×2 alkaline battery
- 3) Indicator for ready: Green
- 4) Measurement range: 0.0mg/d L ~ 32.0 mg/d L
- 5) Measurement accuracy: Range is ±1.5 mg/d L (±25.5 μmol/L)
- 6) Charging preparation time: < 12 seconds
- 7) Record function: record 21 previous measurement values and review recorded data
- 8) Repeatability: < 10%

4 Preparations before Use

4.1 Basic Knowledge

In order to prevent neonatal nuclear jaundice, it is very important to diagnose pathological jaundice as early as possible.

The concentration of transcutaneous bilirubin can be tested instantly and non-invasively by placing the probe on the neonatal forehead or sternum and pressing gently. It is suitable for neonatal jaundice screening. Though transcutaneous bilirubin is a very close correlation with the serum bilirubin concentration, there will be some difference between the measurement value and serum bilirubin concentration in the conditions noted below.

4.1.1 Precocious Jaundice

If there is a possibility that the newborn infant is suffering from precocious jaundice (incompatible blood type, hemolytic jaundice), it is necessary to take frequent measurements or measure the total serum bilirubin concentration as well. (There is a possibility that bilirubin concentration in the subcutaneous tissue rises slower than the total serum bilirubin concentration)

4.1.2 When the Newborn Infant Is Undergoing Phototherapy

During phototherapy, the bilirubin concentration in the subcutaneous tissue under the area exposed to light decreases before the total serum bilirubin concentration does, so it is necessary to limit the use of this instrument only when phototherapy equipment is used from the back of the patient, or by affixing a light-blocking patch to the measuring point on the forehead or chest. (In areas exposed to light, there are some cases in which only the bilirubin concentration in the subcutaneous tissue decreases before the total serum bilirubin concentration improves. In addition, if the total serum bilirubin concentration increases again after therapy, there is a possibility that the bilirubin concentration in the subcutaneous tissue will increase later.)

4.1.3 Measurement Points

Measurements must be taken on the forehead or sternum, where a sufficient amount of blood is circulated. (There is a chance that the bilirubin concentration in the subcutaneous tissue is low for areas with small amounts of blood and areas in which the subcutaneous tissue is subject to keratinisation.)

4.2 Attention During Operation

1) This instrument must be used for newborn infants only. It is designed for estimating total serum bilirubin concentration that is necessary for the screening of jaundice in newborn infants.

2) When used in combination with phototherapy equipment, it may lead to misdiagnosis.

3) This instrument should be used under the following operating conditions: Temperature of 10°C to 40°C, relative humidity less than 85%, with no condensation.

4) This instrument is a precision instrument, so it should not be dropped, exposed to shocks and strong vibrations, nor should heavy objects be placed on it. Failure to observe these attentions may cause breakage.

5) Do not hang transfusion or infusion liquid near the device.

6) Do not use the instrument on a point where there is direct sunlight and excessive vibration. In addition, avoid excessive impact on the instrument. Failure to observe this may cause breakage.

7) This instrument emits intense light to take measurements. Measurements should only be taken on the forehead or sternum, and the instrument should never be allowed to emit light directly into the eyes.

8) If the instrument gets dirty, wipe it with a dry cloth or a cloth moistened with mild, neutral detergent. (Never use a solvent such as thinner or benzene to clean the instrument, as it may dissolve its casing.)

9) The measuring probe should be cleaned by wiping with medicinal alcohol before use.

4.3 Operation Location

This product can only be used indoors.

⚠ WARNING: Ⓞ Jaundice Meter should not be used in situations that include environmental vibration, dust, corrosive or flammable, explosive gas (anesthetic gas, gasoline), extreme temperatures and humidity, and there is enough space for easy operation.

⚠ ATTENTION: Ⓞ Ambient temperature exceeding the range of technical specification will affect the jaundice detector accuracy, resulting in machine damage and reducing the device life.

4.4 Check Battery

Check the battery status before use. The correct method is to press the Reset Button, and if the indicator light does not turn green within 12 seconds, replace the battery. Battery replacement method is as follows:

Prepare 2 batteries (AA1.5V), open the battery casing cover at the back of detector, fix batteries and close battery casing cover (See figure 4-1).

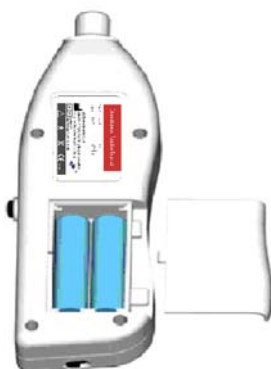

Figure 4- 1 Battery installation method

After each measurement, switch power off.

- ⚠ ATTENTION: ⚠ Insert batteries as indicated.**
 - ⚠ ATTENTION: ⚠ When Low Battery indicator appears, replace batteries.**
 - ⚠ ATTENTION: ⚠ Remove the batteries when the device is not in use for extended times.**
 - ⚠ ATTENTION: ⚠ The battery should be disposed in accordance with local regulations.**
 - ⚠ ATTENTION: ⚠ Energizer batteries are recommended.**
-

5 Operation Instructions

- 1) Remove the device from the box, and unplug the probe hat.
- 2) Wipe the measuring probe with Alcohol Wipe.

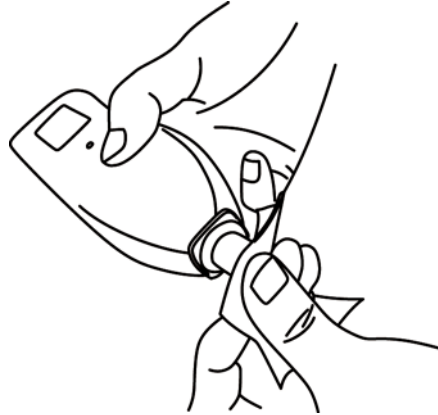

Figure 5- 1 Wipe the detector probe

- 3) Turn power switch to "ON". The system will first display system version number, as shown in figure 5-2. It will then display measurement "00.0", as shown in figure 5-3.



Figure 5- 2 Display system version number



Figure 5- 3 Measurement interface

- 4) Press the "Reset" button to start charging. The green ready indicator will light up after a few seconds, as shown in figure 5-4.



Figure 5- 4 Interface ready to test

5) Ensure that the detector probe vertically touches the patient's measuring point. Then press it gently until the probe flashes.

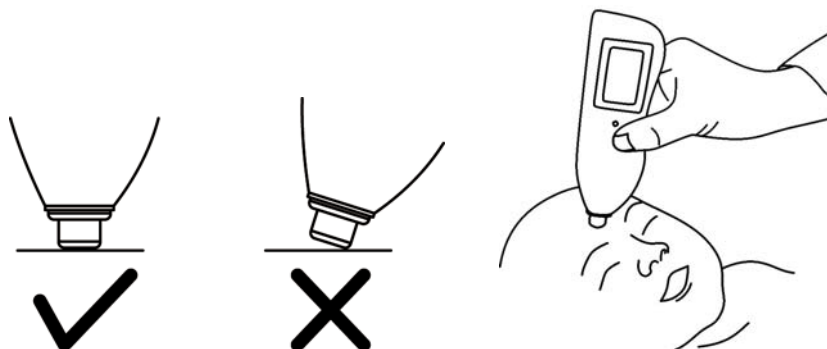

Figure 5- 5 Correct measurement method

⚠ ATTENTION: **📌**Note that the probe and the measurement point must be vertical, as shown in Figure 5-5, otherwise there may be a measurement error.

⚠ WARNING: **🚫**To avoid eye injury, the instrument should never be allowed to emit light directly into the eyes.

⚠ ATTENTION: **📌**During testing, the operator must ensure that the probe is perpendicular to the test point and the entire end face of the probe is against the skin without any gap, otherwise the test results may be invalid.

6) Then display measurement value on the LCD screen.



Figure 5- 6 Measurement results screen

⚠ ATTENTION: **📌**If the green ready light is on, and patient measurement is not performed, the device does not self-discharge. The user should put the probe hat on, and press probe to discharge.

7) To measure again in accordance with step 4) to 6), the screen display is similar to figure 5-6, and the serial number will increase, shown in figure 5-7.



Figure 5- 7 Repeated measuring interface

- 8) Slide the power switch to "OFF".
- 9) Put the device back into the box.

6 User Recommendations for Use During and After Phototherapy

6.1 During Phototherapy

6.1.1 Eye Patches

Take precautions to ensure that the eye patches cover a large portion of the forehead, especially the site at which the MBJ20 measurement will be taken. Secure the eye patches to prevent them from moving and exposing the measurement site to the phototherapy lights. Shown in figure 6-1.



Figure 6- 1 Eye patches put on the forehead

(⊗ Recommended measurement site)

6.1.2 Adhesive Skin Patches

Place the adhesive skin patch on the forehead at an anatomic site, such as between the infant's eyebrows. Shown in figure 6-2.

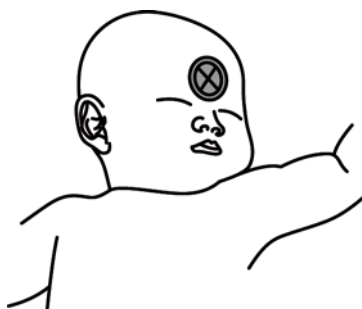

Figure 6- 2 Adhere eye patches on the middle of forehead

(⊗ Recommended measurement site)

⚠ ATTENTION: **!** Select the site at which the MBJ20 measurement will be taken. The preferred site is the flat area of the forehead

between the infant's eyebrows.

⚠ ATTENTION: ⚠ A photo-opaque material must be positioned over the measurement site on the forehead prior to the start of phototherapy. Any necessary preATTENTIONs should be taken to ensure that the material does not move in such a way as to expose the measurement site to the phototherapy lights.

⚠ ATTENTION: ⚠ All phototherapy lights should be turned off while a MBJ20 measurement is taken.

6.2 After Phototherapy

Appropriate measures should be taken to ensure that any measurements taken from newborns after they have received phototherapy are taken from a site on the forehead that was not exposed to the phototherapy lights. We recommend using the method described in section 6.1.1 to protect the measurement site, and to ensure the protection of the same site during phototherapy, which will improve accuracy of measurements.

⚠ ATTENTION: ⚠ Clinical studies indicate that as many as 48 hours may be required before the skin treated by phototherapy returns to the bilirubin level of an unexposed site.

⚠ ATTENTION: ⚠ Newborns that are placed near windows with high exposure to sunlight may experience “natural phototherapy”. This may be particularly true when the newborn has already been discharged home and is returning to a hospital, clinic, or office facility for testing.

7 Special Operation

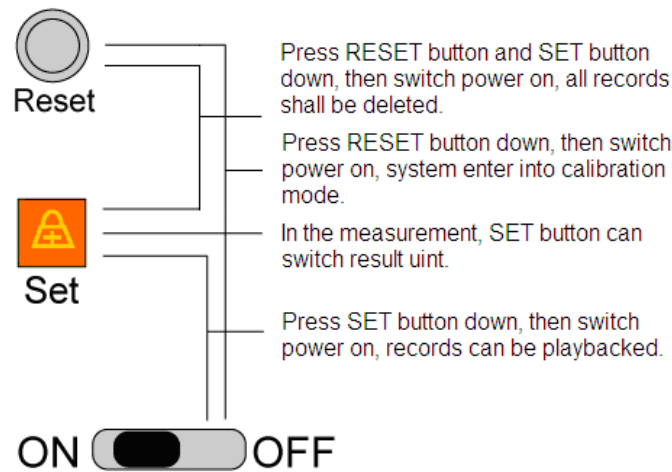

Figure 7- 1 Combination keys explanation

7.1 Data Deletion

Press “RESET” and “SET” together, then turn on the power switch. When MBJ20 is turned on, enter data deletion mode. The screen content is like figure 7-2.



Figure 7- 2 Clearing records in instrument

Turn on the device to test

⚠ATTENTION: **!** it will delete all data, so please operate carefully

7.2 Unit Conversion

Press “SET” to convert units when measurement is finished.

Press “SET” when measurement unit is “mg/dL” and then convert to be “ μ mol/L” and data converted appears on screen. (Shown in figure 7-3) Press “SET” and data units will change accordingly.



Figure 7- 3 Conversion of unit

7.3 Records Playback

Press the key “SET” with power on, and then enter the playback mode, as shown in figure 7-4. The latest recording is initially shown on the screen, then press the key “SET” or “RESET” to review previous records. The device will save 21 measurements.



Figure 7- 4 Playback of records - record saved

If there is no records measurements, enter into playback mode, as shown in figure 7-5



Figure 7- 5 Playback of records - no record

7.4 Calibration

7.4.1 Settings of Calibration Coefficient

- 1) Enter calibration mode: press RESET button, then switch power on, a value is displayed on screen. This value is the current calibration coefficient (using upper case letter “Y” to represent);
- 2) Set calibration coefficient: If you wish to change the coefficient, press SET button to increase, or press RESET button to decrease the

variation range between -9.9~9.9 of the original coefficient value. Shown as figure 7-6.

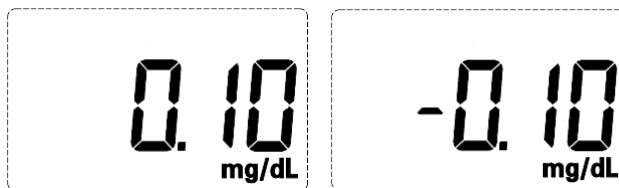

Figure 7- 2 Proportionality adjust for calibration coefficient - decrease or increase

3) Save calibration coefficient: when the new coefficient is chosen, press probe down for 2 seconds, at the same time, the indicator Ready light and there is a lock symbol appears in the screen which means the new coefficient saved. Shown as figure 7-7



Figure 7- 7 Calibration Baseline

7.4.2 Calibration Method

- 1) When measurement of the device is not accurate, user can calibrate it based on the total bilirubin measured in testers' blood analysis.
- 2) The calibration procedure: firstly, record a tester's total bilirubin (represented with A) from blood analysis, and then use Jaundice Detector to test his jaundice (represented with B). Lastly, calculate the calibration coefficient $Y=A - B$;
- 3) Save calibration coefficient according to Section 7.4.1.
- 4) If user does not save the calibration coefficient, then the total bilirubin can be corrected by referring to the following formula:

$$\text{Total Bilirubin A (mg/dL)} = \text{Transcutaneous Jaundice B (mg/dL)} + \text{Calibration Coefficient Y (mg/dL)}$$

7.5 Average Test Function

7.5.1 Average Times Setting

In the condition of turn off, press the probe as well as turning on the device. By this way can enter the average times setting status. The last recorded average times setting will appear in the screen. The average times value shall be changed and set circularly from 1 to 9 by pressing the key of 'RESET'. Shown as figure 7-8

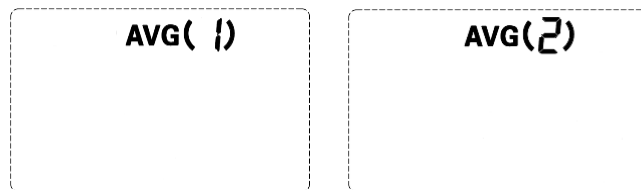

Figure 7- 8 Revise the average times

When the average times is set, confirm and record the setting by pressing the key of 'SET' and then the indicator of 'Ready' will be on and there appears a lock symbol in the screen. Shown as figure 7-9

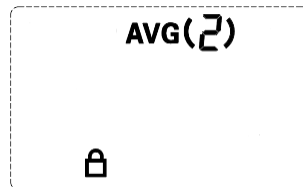

Figure 7- 9 Save Average Times

7.5.2 The Average Test Method

When the average test times setting is finished, restart the device, press "RESET" to test, the value on the right is the average test times. Shown as 7-10. The test result will not appear if only one time test is done, while the right value will decrease by 1. Show as 7-11



Figure 7- 10 Average Test process

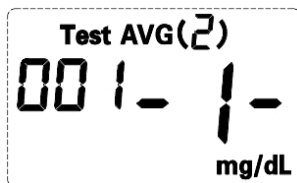

Figure 7- 11 Average Test process

After finished the average test times, it will show the average test result which is the average for the previous measurement. Show as 7-12

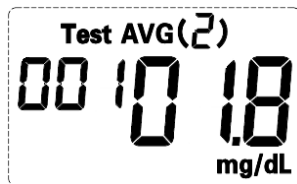

Figure 7- 12 Average Test process

8 Maintenance

8.1 Biocompatibility

In case that the device is operated under the guideline of the user manual, all product parts contacting with the patient's body have reached the standard requirements of biological compatibility. If you have any questions about it, please contact our company or your local representative.

8.2 Daily Inspection

Check whether there is any obvious physical damage on the device or any broken parts to be replaced. Only service technician authorized by M&B can repair and replace the parts.

Before using MBJ20, check whether there is any intuitive mechanical damaged parts each time. If the mal-functions of MBJ20 are found out, please ensure to repair before use, avoiding causing the patient or operator injured.

8.3 Storage Method

1) For storage and operation of the device, refer to section 1.5, 1.6. Please avoid putting the device in an environment of high temperature or humidity.

2) Do not store the instrument in an area where it will be exposed to water.

3) Do not store the instrument in an area where direct sunlight, pressure, temperature, humidity, ventilation, sunlight, dust, strong magnetic fields, and/or saline or sulphurous atmospheres may affect the instrument.

4) Do not store the instrument on an inclined surface or on a surface which may be subject to vibrations or physical shock. (Also avoid vibrations or physical shock during transportation.)

5) Do not store the instrument in areas where chemicals are stored or where gas may be emitted.

6) The instrument and its accessories should be cleaned thoroughly and

stored properly to make sure that there will be no problems when they are used again. (For the cleaning method, refer to section 8.4.2)

8.4 Maintenance Plan

The maintenance plan must follow the rules of the local infection control institute and (or) biomedical department.

⚠ WARNING: ⚠ If the hospitals or departments that use MBJ20 jaundice detector do not implement a reasonable maintenance plan, it may lead to serious equipment failure.

Please consult your biomedical department to ensure proper implementation of preventive maintenance and calibration measures. This manual includes a detailed description.

8.4.1 Inspecting Device

8.4.1.1 Standards of Inspecting Device

1) Checking whether there is any obvious physical damage of the equipment, and inspect any damaged parts. Only authorized personnel can repair devices or replace parts.

2) If the device is not in use, the battery will discharge. Remove the batteries to store.

8.4.1.2 Inspection Before Use

- 1) Check the battery installation.
- 2) Check the working condition of buttons, LCD and probe.
- 3) Clean the measuring probe with medicinal alcohol.

8.4.2 Regular Cleaning

⚠ WARNING: ⚠ Turn the switch to “OFF” and take the battery out before cleaning.

8.4.2.1 Shell

1) Devices should be cleaned regularly. Please follow the rules of local infection control institute and biomedical department.

2) The outer surface of device should be cleaned by a lint-free damp cloth.

To avoid damaging the equipment, please follow the regulations as below:

⚠ ATTENTION: ⚠ Unless you follow these guidelines, you may damage the case by deformation or tarnishing, make the label unclear or even cause equipment failure.

3) Do not use cleaning material containing paraffin.

4) Do not pour or inject any water or cleaning liquor into the device, and also prohibit liquid flowing to power switch, connector or any gaps.

⚠ WARNING: ⚠ The following cleansers are prohibited: Solvent, acetone, ketone, or any cleanser which is mainly consisting of alcohol or betadine.

8.4.2.2 Display screen

Please use a soft cloth with glass cleaner to clean the display screen. Do not spray the glass cleaner directly onto the display screen, and do not use alcohol or medical disinfectant (such as betadine).

8.4.3 Other Maintenance and Service

1) Put the instrument in a cool and dry place away from direct sunshine when not in use.

2) Clean the probe with medicinal alcohol frequently.

8.5 Technical Service

8.5.1 Technical Maintenance

Our company will provide the related technical manuals if required, including circuit diagrams, component list and technical description.

8.5.2 Technical Inspection

For the safety of MBJ20 function and operation, please perform a periodic inspection. Technical inspection should be performed annually. This inspection should be carried out by a trained representative. If required, our company will implement inspections and maintenance for you under a service agreement.

8.6 The replacement of Accessories and Consumable Materials

⚠ ATTENTION: ⚠ Waste of electrical and electronic equipment must not be disposed as unsorted municipal waste and must be collected separately.

⚠ ATTENTION: ⚠ Turn the power switch to “OFF” before changing consumable materials.





The device’s only consumable material is the batteries. Please read section 4.4 about replacing batteries.

8.7 Diagnosis of Device Malfunction

When there is something wrong for the device, please deal with it according to the below table. If can not back to the normal status, please contact our company or respective.

Table 8- 1

| Malfunction Content | Reason | Solution |
|---|---|---|
|  | Test object or test place is unreasonable, which make there is some problem for | Please test according to the device required object and place |

| | | |
|--|---|--|
| | the signal | |
|  | Test object or test place is unreasonable | Change the test object to retest |
| | hardware malfunction | Turn off, after 10 seconds, tun on. If the problem is still there, pls contact our company or representative |
|  | hardware malfunction | |
|  | Test result exceed the maximum range | Change the test object to retest |
|  | Battery is low | Insert new batteries |
| After pressing REST key, the indicator light" Ready" is still off | Battery is low | Insert new batteries |
| | Hardware malfunction | contact our company or representative |
| Turn on, still no display, or suddenly disappear show during testing | Battery is low | Insert new batteries |

9 Guidance and Manufacturer’s Declarations

| Electromagnetic Emissions | | |
|--|-------------------|---|
| <p>The MBJ20 transcutaneous jaundice detector is intended for use in the electromagnetic environment specified below. The customer or the user of the device should ensure that it is used in such an environment.</p> | | |
| Emissions test | Compliance | Electromagnetic environment – guidance |
| RF emissions CISPR 11 | Group 1 | The MBJ20 transcutaneous jaundice detector uses RF energy only for its internal function. Therefore, its RF emissions are very low and are not likely to cause any interference in nearby electronic equipment. |
| RF emissions CISPR 11 | Class A | The MBJ20 transcutaneous jaundice detector is suitable for use in all establishments, other than domestic establishments and power supply is internal. |

| Electromagnetic Immunity | | | |
|--|-----------------------------|-------------------------|---|
| <p>The MBJ20 transcutaneous jaundice detector is intended for use in the electromagnetic environment specified below. The customer or the user of the device should ensure that it is used in such an environment.</p> | | | |
| Immunity test | IEC 60601 test level | Compliance level | Electromagnetic environment–guidance |
| Electrostatic discharge (ESD) IEC 61000-4-2 | ±6 kV contact | ±6 kV contact | Floors should be wood, concrete or ceramic tile. If floors are covered with synthetic material, the relative humidity should be |
| | ±8 kV air | ±8 kV air | |

| | | | |
|---|---------------------------|-------|---|
| | | | at least 30 %. |
| Power frequency (50/60 Hz) magnetic field IEC 61000-4-8 | 3 A/m | 3 A/m | Power frequency magnetic fields should be at levels characteristic of a typical location in a typical commercial or hospital environment. |
| Radiated RF IEC 61000-4-3 | 3V/m 80 MHz to 2.5 GHz | 3 V/m | $d = 2.3 \cdot \sqrt{P} \quad 800$ <p>MHz to 2,5 GHz</p> <p>where P is the maximum output power rating of the transmitter in watts (W) and d is the recommended separation distance in meters (m)^b.</p> <p>Field strengths from fixed RF transmitters, as determined by an electromagnetic site survey,^a should be less than the compliance level in each frequency range.^b</p> <p>Interference may occur in the vicinity of equipment marked with the following symbol:</p>  |

- a. Field strengths from fixed transmitters, such as base stations for radio (cellular/cordless) telephones and land mobile radios, amateur radio, AM and FM radio broadcast and TV broadcast cannot be predicted theoretically with accuracy. To assess the electromagnetic environment due to fixed RF transmitters, an electromagnetic site survey should be considered. If the measured field strength in the location in which MBJ20 transcutaneous jaundice detector is used exceeds the applicable RF compliance level above, MBJ20 transcutaneous jaundice detector should be observed to verify normal operation. If abnormal performance is observed, additional measures may be necessary, such as reorienting or relocating MBJ20 transcutaneous jaundice detector.
- b. Over the frequency range 150 kHz to 80 MHz, field strengths should be less than 3 V/m.